



IMU383ZA

HIGH PERFORMANCE, FAULT TOLERANT
INERTIAL MEASUREMENT SYSTEM

The IMU383ZA is a pin-compatible replacement for the popular IMU380ZA and IMU381ZA Inertial Measurement Units. The IMU383ZA offers improved performance, in addition to a unique fault-tolerant sensor architecture for improved reliability. Other key features include advanced synchronization, and a bootloader for field upgradeability.



Precision Farming



Platform Stabilization

The ACEINNA IMU383ZA integrates highly-reliable MEMS 6DOF inertial sensors in a miniature factory-calibrated module to provide consistent performance through the extreme operating environments in a wide variety of dynamic control and navigation applications.

Features

- Complete 6DOF Inertial System
- Fault-tolerant, 3x redundant sensors
- Bootloader for field upgrades
- SPI (or UART) Interface
- Update Rate, 1Hz to 200Hz
- 1 KHz Clock Sync Input
- Miniature Package, 24 x 37 x 9.5 mm
- Drop-in upgrade for IMU380/381ZA
- Low Power Consumption < 250 mW
- Wide Temp Range, -40C to +85C
- High Reliability, MTBF > 50k hours

Applications

- Unmanned Vehicle Control
- Precision Agriculture
- Platform Stabilization
- Robotics Control

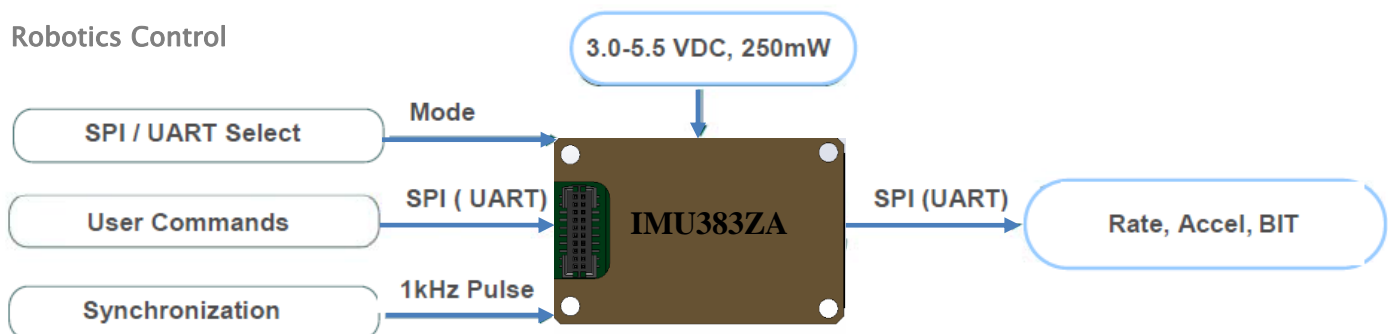

IMU383ZA

HIGH PERFORMANCE, FAULT TOLERANT
INERTIAL MEASUREMENT SYSTEM

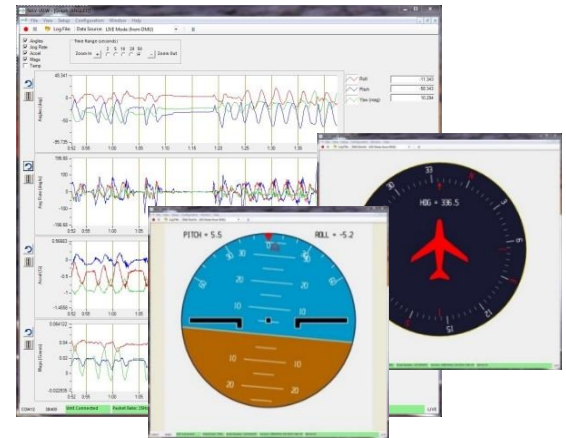

NAV-VIEW provides an easy to use graphical interface to display, record, playback, and analyze all of the IMU383ZA system parameters.

NAV-VIEW can also be used to set a wide range of user-configurable fields in the IMU383ZA to optimize the system performance for highly dynamic applications.

NAV-VIEW software is available for download from ACEINNA's website at: www.aceinna.com/support

EVAL KIT

The IMU383ZA evaluation kits include an IMU383ZA, evaluation / interface board and USB cable allowing direct connection to a PC for use with NAV-VIEW display and configuration software.



Support

For more detailed information please refer to the IMU383ZA Series User's Manual available online at:

www.aceinna.com/support

Performance IMU383ZA-400

Angular Rate	
Range: Roll, Pitch (°/sec)	± 400
Bias Instability (°/hr) ^{1,2}	1.3
Bias Stability Over Temp (°/sec)	< 0.5
Resolution (°/sec)	< 0.02
Scale Factor Accuracy (%FS)	< 0.1
Non-Linearity (%FS)	< 0.1
Angle Random Walk (°/√hr) ^{1,2}	0.08
Bandwidth (Hz)	5-50 (user-configurable)
Acceleration	
Range: X, Y, Z (g)	± 8
Bias Instability (mg) ^{1,2}	0.015
Bias Stability Over -40C~ 85C (mg)	< 5
Resolution (mg)	< 0.5
Scale Factor Accuracy (%FS)	< 0.1
Non-Linearity (%FS)	< 0.1
Velocity Random Walk (m/s/√hr) ^{1,2}	0.02
Bandwidth (Hz)	5-50 (user-configurable)

Other Specifications

Environment	
Operating Temperature (°C)	-40 to +85
Non-Operating Temperature (°C)	-55 to +105
Enclosure	Die-Cast Aluminum
Electrical	
Input Voltage (VDC)	3.0 to 5.5
Power Consumption (mW)	< 250
Digital Interface	SPI or UART (user-configurable)
Output Data Rate	1Hz to 200Hz (user-configurable)
Input Clock Sync	1kHz Sync Pulse
Physical	
Size (mm)	24.15 x 37.7 x 9.5
Weight (gm)	< 17
Interface Connector	20-Pin (10 x 2) 1.0 mm pitch header

Ordering Information

Model	Description
IMU383ZA-400	Inertial Measurement Unit (6 DOF, 400dps Range)
IMU383ZA-400 EVK	Evaluation Kit for IMU383

This product has been developed exclusively for commercial applications. It has not been tested for, and makes no representation or warranty as to conformance with, any military specifications or its suitability for any military application or end-use. Additionally, any use of this product for nuclear, chemical or biological weapons, or weapons research, or for any use in missiles, rockets, and/or UAV's of 300km or greater range, or any other activity prohibited by the Export Administration Regulations, is expressly prohibited without the written consent and without obtaining appropriate US export license(s) when required by US law. Diversion contrary to U.S. law is prohibited. Specifications are subject to change without notice.

¹ Allan Variance Curve, constant temperature. ² mean + 1-sigma of production population.